

# Yan Chai Hospital Lim Por Yen Secondary School

## AL Physics Assignment

1. Motion along straight line, relative motion and projectile motion	1
2. Newton's Law of motions.....	4
3. Circular motions .....	6
4. Simple Harmonic Motion .....	9
5. Gravitational Field.....	12
6. Solids .....	15
7. Bernoulli's Principle and Heat & Energy.....	17
8. Wave Motion & Acoustics.....	20
9. Physical Optics.....	23
10. Geometric Optics.....	26
11. Electric Field & Potential.....	29
12. Capacitance.....	33
13. Current Electricity .....	37
14. Electromagnetism .....	40
15. Alternating Currents .....	44
16. Extra-nucleus Physics .....	47
17. Radioactivity& Nuclear Physics .....	51

Name: \_\_\_\_\_

Class: \_\_\_\_\_ ( )

Year: 2008/2010

Teacher: Mr. King

## Table of contents

<i>Chapter</i>	<i>Date</i>	<i>Grade</i>
Motion along straight line, relative motion and projectile motion		
Newton's Law of motions		
Circular motions		
Simple Harmonic Motion		
Gravitational Field		
Solids		
Bernoulli's Principle and Heat & Energy		
Wave Motion & Acoustics		
Physical Optics		
Geometric Optics		
Electric Field & Potential		
Capacitance		
Current Electricity		
Electromagnetism		
Alternating Currents		
Extra-nucleus Physics		
Radioactivity & Nuclear Physics		

1. Motion along straight line, relative motion and projectile motion

1. A student is running to catch the campus shuttle bus, which is stopped at the bus stop. The student is running at a constant speed of  $6.0 \text{ m s}^{-1}$ ; she cannot run any faster. When the student is still  $60.0 \text{ m}$  from the bus, it starts to pull away. The bus moves with a constant acceleration of  $0.180 \text{ m s}^{-2}$ .

- a) For how much time and what distance does the student have to run before she overtakes the bus?

- b) When she reaches the bus, how fast is the bus traveling?

- c) Sketch a graph showing  $x(t)$  for both the student and the bus. Take  $x = 0$  as the initial position of the student.

- d) The equations that you used in part (a) to find the time have a second solution, corresponding to a later time for which the student and bus are again at the same place if they continue their specified motions. Explain the significance of this second solution. How fast is the bus traveling at this point?

e) If the student's constant speed is  $4.0 \text{ m s}^{-1}$ , will she catch the bus?

f) What is the *minimum* speed the student must have to just catch up with the bus? For what time and what distance does she have to run in that case?

2. A river flows with a uniform speed  $v_r$  relative to the ground. Its width is PQ. A man wishes to go from P to Q. He drives a motor boat that runs at a constant speed  $v_b$  relative to the water. Since there is a water current, he cannot go directly across the river. Instead he lands at a point R which is 100m downstream from Q. The journey takes him 10 min. If he wants to arrive at Q, he has to direct the boat upstream at an angle  $\theta$ . This journey takes him 15 min.

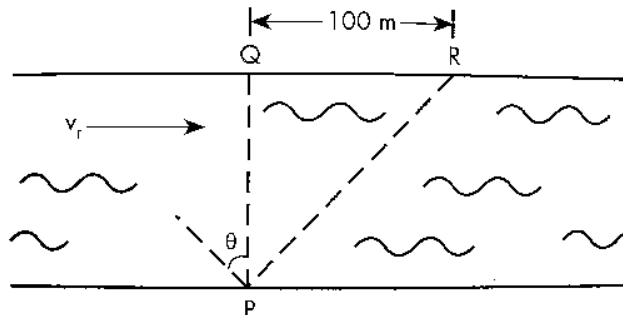

a) What is the velocity of the water current  $v_r$  relative to the ground?

b) Draw a vector diagram to show the relationship between the velocity of the water current  $v_r$ , the velocity of the boat relative to the water  $v_b$  and the resultant velocity  $v$  of the boat when the man directs the boat upstream at an angle  $\theta$ .

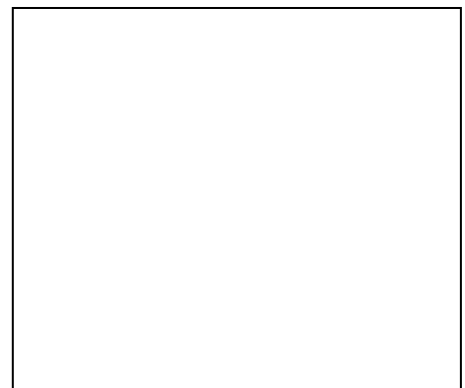

c) At what angle  $\theta$  should the man aim the boat so that he can reach Q from the starting point P?

d) Use the above results to find the speed of the motor boat  $v_b$ .

e) Hence determine the width of the river.

3. A block, mass 0.5kg, slides down from rest along a frictionless track as shown in the figure. After it has left the circular portion of the track, it flies in the air like a projectile and finally lands on a plate. Assume that the air resistance is negligible.

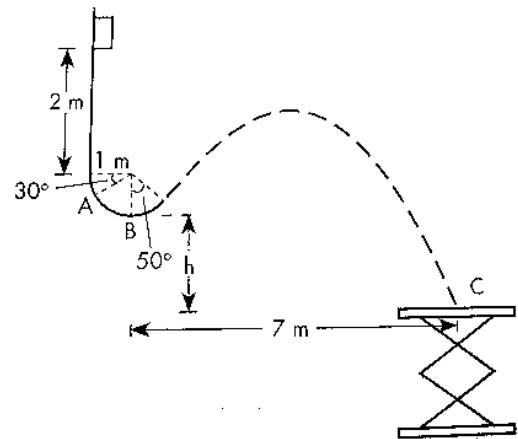

a) Find the velocity of the block when it has just left the circular portion of the track.

b) Hence, or otherwise, determine the value of h.



2. Newton's Law of motions

1.

a) Explain the meanings of Newton's second and third Laws of Motion.

b) Apply these laws to the rapid impact between two bodies, which were initially moving with unequal velocities along the same direction, and show that linear momentum is conserved. Explain whether the total kinetic energy is necessary conserved or not.

2. A block  $m_1$ , mass 30kg, is placed on the top of another block  $m_2$ , mass 20kg, as shown in the figure. The coefficient of friction between all surfaces in contact is  $\mu = 0.25$  and the force  $F$  applied to block  $m_1$  is 350N.

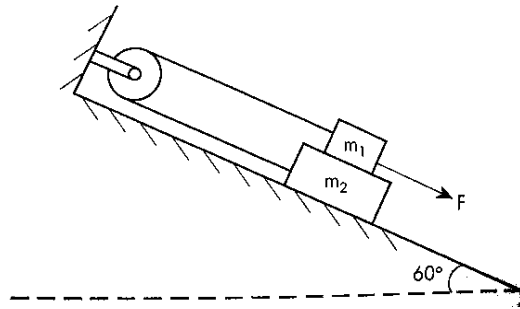

- a) Draw the free body diagrams for blocks  $m_1$  and  $m_2$ .

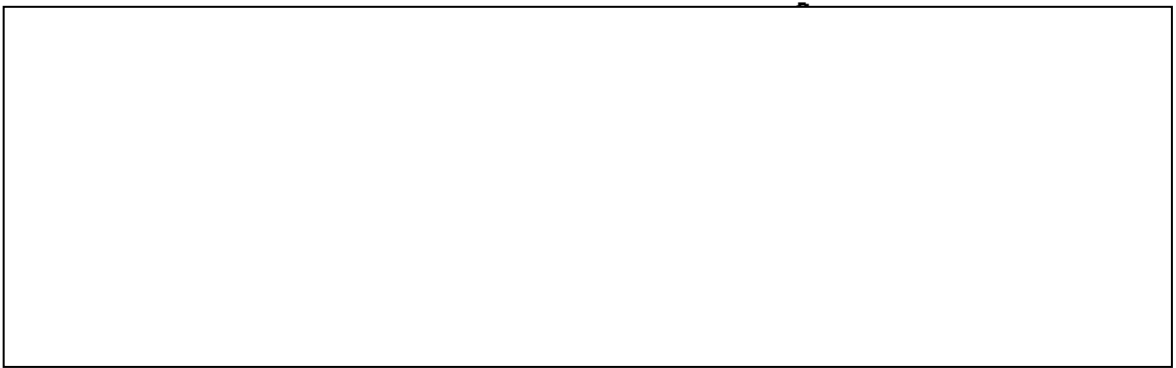

- b) Determine the acceleration of block  $m_2$ .  
c) Hence, or otherwise, determine the tension in the rope.

- d) Compute the force that the pulley exerts on the wall.

3. Circular motions

1. Two marbles **A** and **B**, of equal mass  $m$ , are performing circular motions inside a smooth conical container. They are at  $r_A$  and  $r_B$  respectively from the axis.

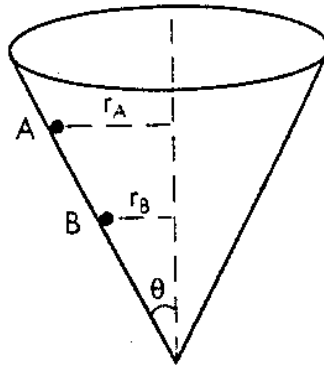

- a) Draw a free body diagram for one of the marbles.

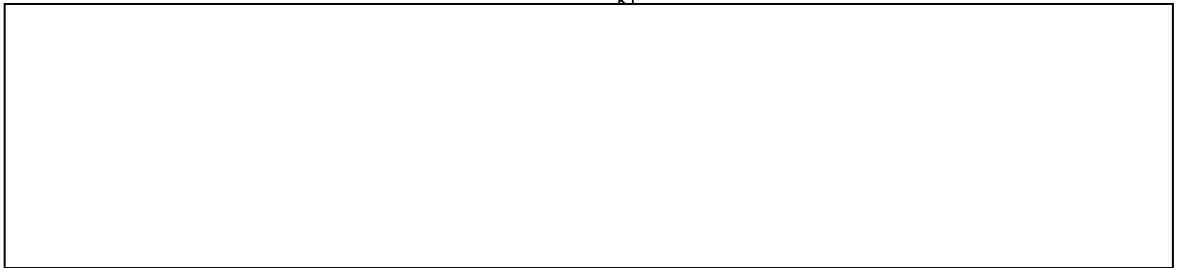

- b) Deduce a general expression for the tangential velocity  $v$  of the marble in terms of  $\theta$ ,  $r$  and  $g$  where  $r$  and  $g$  are the distance of the marble from the axis and the acceleration due to gravity respectively.

- c) Hence, or otherwise, determine
- i) which marble has a higher tangential velocity,
  
  
  
  
  
  
  
  - ii) which one has a larger angular velocity,
  
  
  
  
  
  
  
  - iii) which one has a longer period of rotation,



iv) which one experiences a greater normal reaction from the container.

2.

a) A racing car is travelling at a constant speed  $v$  on a horizontal curved path of radius  $r$ . The coefficient of friction between the tyres and the surface of the road is  $\mu$ . The mass of the car is  $m$ .

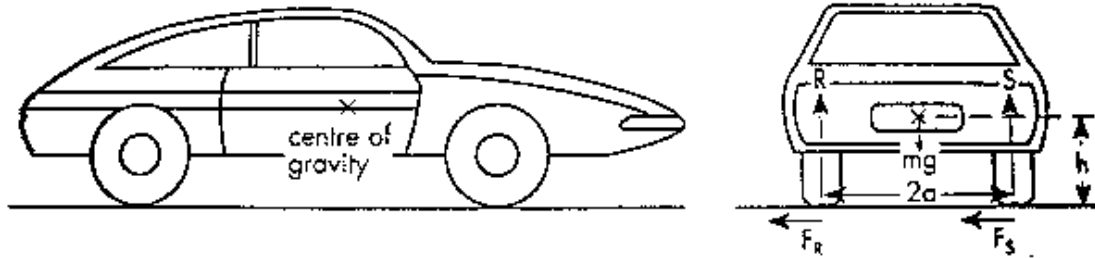

(a) side view

(b) back view

i) If the car is to negotiate this path without skidding, derive an expression (in terms of  $\mu$ ,  $r$ ,  $h$ ,  $g$  and  $a$ ) for its maximum speed.

ii) Repeat part (a)(i) but this time the car is to negotiate the path without overturning.

iii) Using the results in parts (a)(i) and (ii), state the limitation factors.

b) A circular speed track has a radius of 125m. The banking angle is  $26.5^\circ$ . If the coefficient of static friction between the tyres and the track under the prevailing conditions is 0.25, find

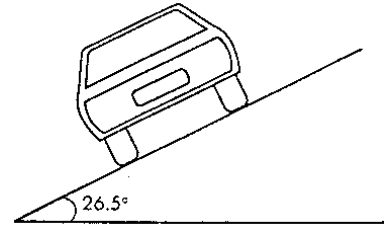

i) the minimum speed and

ii) the maximum speed at which the car can negotiate the track without slipping.

4. Simple Harmonic Motion

1.

a) A point **P** moves in a circular path, around **O** as centre, with a constant angular velocity  $\omega$ .

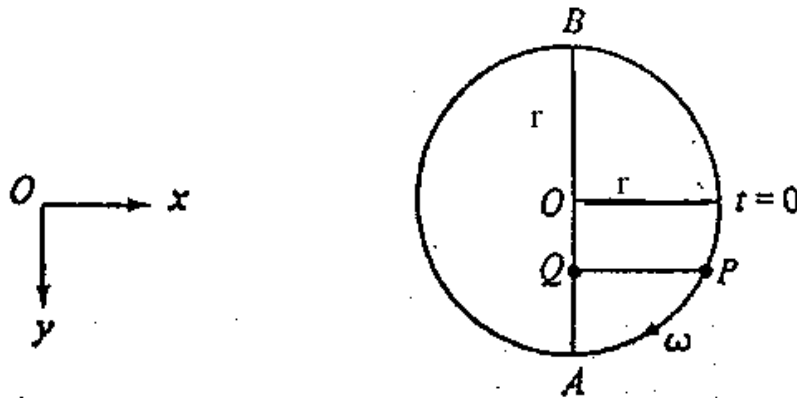

i) Show that point **Q**, the projection of **P** on the diameter **AB**, moves with an acceleration towards **O** and that the magnitude of the acceleration is proportional to the displacement of **Q** from **O**. (**O** is the starting position for time  $t = 0$ )

ii) Write down mathematical expressions for

- (1) the displacement of **Q** from **O**,
- (2) the velocity of **Q**,
- (3) the acceleration of **Q**, at any subsequent time  $t$ .

- iii) Hence, using the same time axis, plot the variations of (1), (2) and (3) with time during one complete cycle of motion of  $Q$ .



- b) If  $Q$  represents location of a mass  $m$  suspended from a vertical hanging, light spiral spring which undergoes oscillations in a vertical plane, write down mathematical expressions for the variation with time of
- the kinetic energy, and
  - the potential energy of the system. (The mass of the spring should be ignored.)

Plot the above time variations on a graph directly underneath the previous graph, using a similar scale for the time axis.



2. The lower end of a spring of force constant  $k$  is fixed to a table while the upper end is attached to a platform with a block of mass  $m$  on top of it.

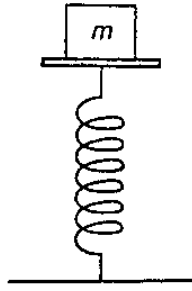

- a) The platform is pulled downwards slightly and then released. If  $m = 5\text{kg}$  and  $k = 1000\text{Nm}^{-1}$ , find the period of the vibration.
- b) Calculate the maximum amplitude of the oscillation if the mass remains contact with the platform all the time.
- c) Determine the maximum potential and kinetic energy of oscillation under part (b) situation.

Sketch a graph to show the variation of kinetic energy with time in one complete cycle.

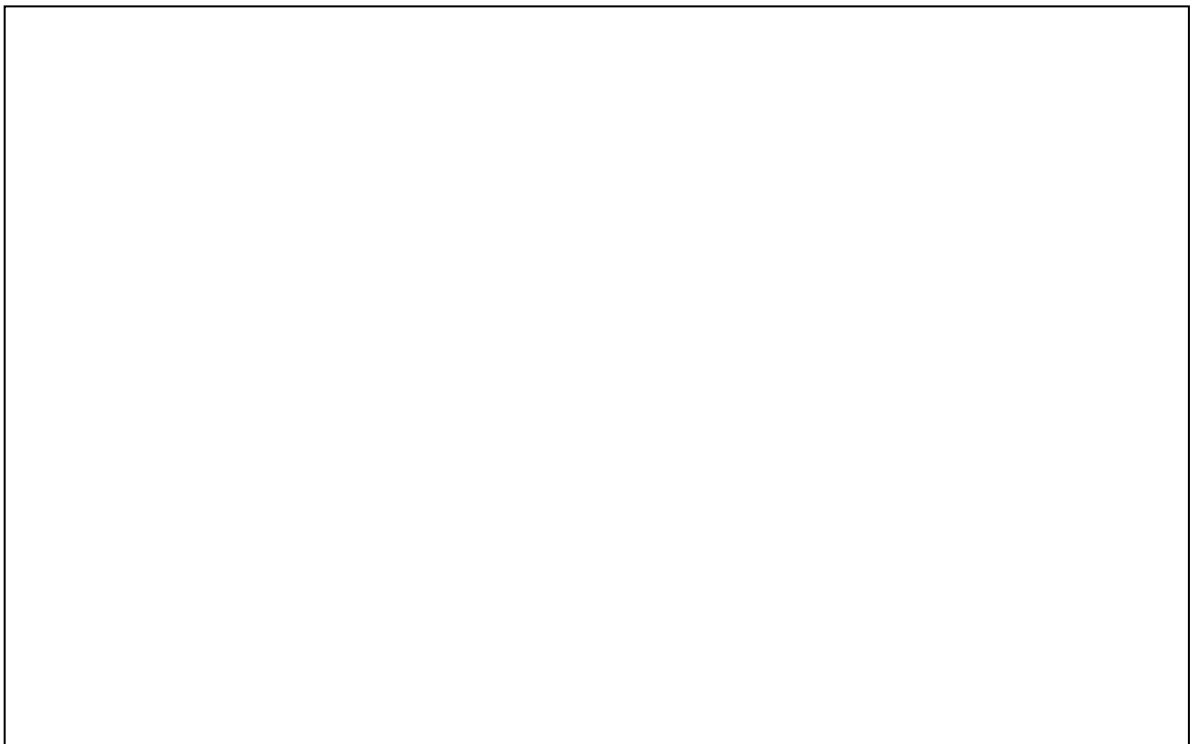

5. Gravitational Field

Given: radius of the earth,  $R_e = 6.37 \times 10^6$  m;  
radius of the moon,  $R_m = 1.73 \times 10^6$  m;  
acceleration due to gravity,  $g = 9.8 \text{ m s}^{-2}$

1. The figure below shows some equipotential lines around the earth. The solid lines represent the paths of various satellites.

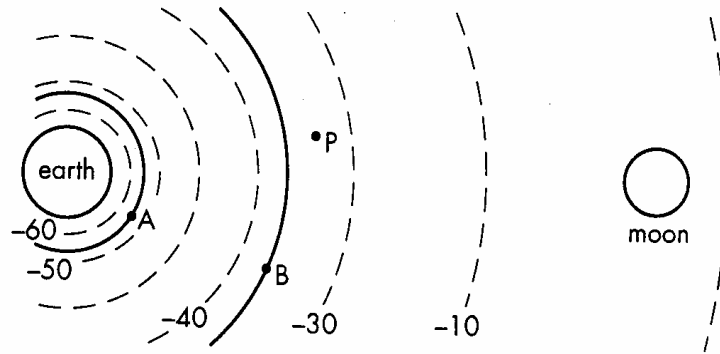

Figure 1

(a) Define 'gravitational potential at a point'.

(b) Explain why

(i) the potential at point P is negative,

(ii) the nearer to the surface of the earth, the closer the spacing of equipotentials.

(c) Satellite A is rotating at a constant speed in a circular path of radius 40 000 km. Satellite B is similarly rotating in a circular path of radius 160 000 km.

(i) Find the ratio of the period of satellite B to that of satellite A.

(ii) Find the kinetic energy per unit mass of satellite A and hence its speed.

(iii) If the gain in potential of satellite C as it reaches the moon is  $30 \text{ MJ kg}^{-1}$  and the mass of satellite C is 5000 kg, how much potential energy has it gained then?

2. The table below shows a number of planets in our solar system.

	Mercury	Earth	Neptune
Period of Revolution	88 days	365 days	165 years
Mean Distance from the Sun (AU)	0.39	1.00	$R_N$
Mass (earth = 1)	$M_{Hg}$	1.00	17.2
Equatorial Diameter / km	4878	12756	48600
Surface Gravity (earth = 1)	0.38	1.00	$g_N$
Density / $\text{g cm}^{-3}$	5.4	$\rho_e$	1.66

(Given: gravitational constant,  $G = 6.67 \times 10^{-11} \text{ N m}^2 \text{ kg}^{-2}$ )

(a) State Kepler's three laws of planetary motion.

(b) By using the laws of motion and the law of universal gravitation, verify the validity of Kepler's third law of planetary motion.

(c) Use the result of part (b) to find the value of the radius of Neptune's orbit,  $R_N$ .

(d) Veilen, an outer space satellite, takes 4895 seconds to complete a circular orbit near the surface of Mercury. What is the mass of Mercury,  $M_{Hg}$ ?



6. Solids

1. Figure 1 shows the force-extension graph for a length of steel wire A. The wire obeys Hooke's law over the range of extension considered.

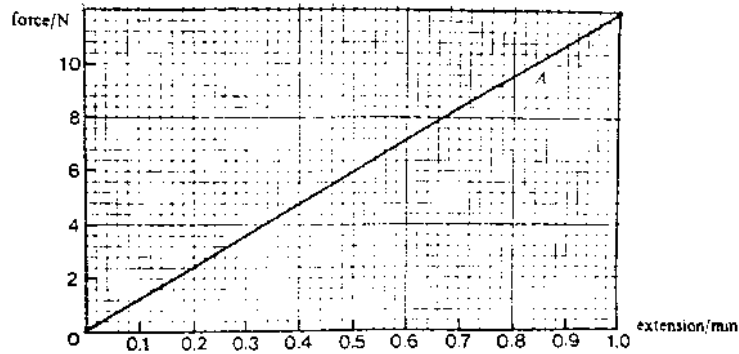

- (a) If the wire has a diameter of 0.40 mm and its unstretched length is 2.0 m, calculate the Young modulus of the steel.
- (b) A second wire B is made of the same steel. It has the same unstretched length as A, but twice the diameter. Draw accurately on the axes of Figure 1 the force-extension graph for this wire. Label your graph B.
- (c) A student discovers that for a given force within the range considered above, the elastic energy stored by wire A is four times greater than that stored by B. Use the two graphs, or some other theoretical argument, to explain this fact.
- (d) If the breaking stress of the steel is  $5.0 \times 10^8 \text{ Nm}^{-2}$ , calculate the maximum force which can be applied longitudinally to wire A.

2. If a typical solid model, layers of atoms are arranged in a cubic square lattice array with each atom at an equilibrium distance  $x$  from its nearest neighbours, both in its own layer and in the layers above or below. Suppose a long steel wire, with many layers, is stretched a little so that each layer is now  $x + \Delta x$  from those above or below it, as illustrated in Figure 2.

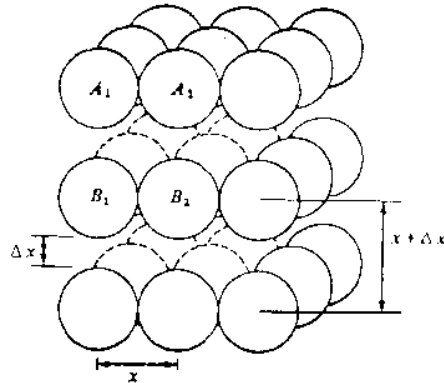

- (a) What is the elastic strain produced?
- (b) Assume that the deformation is elastic, and that the binding force holding the pair of atoms  $A_i$  and  $B_i$  ( $i = 1, 2, \dots$ ) together when the wire is stretched can be considered as acting like a spring.
- If this 'spring constant' is  $k$ , what is the force between the atoms  $A_i$  and  $B_i$ ?
  - If each layer contains  $N$  atoms, what is the total force between pairs of atoms in adjacent planes?
  - Determine the elastic stress acting between the two layers of atoms.
- (c) Use the information in (a) and (b) to determine an expression for the Young modulus of the solid.
- (d) It is known that for steel, Young modulus is  $2 \times 10^{11} \text{ Nm}^{-2}$  and that the interatomic spacing is  $0.30 \text{ nm}$ .
- Estimate a value for  $k$ .
  - Suppose that a steel wire breaks at a tensile stress of  $10^9 \text{ Nm}^{-2}$ , estimate the increase in distance,  $\Delta x$ , between layers of atoms before breaking occurs.

7. Bernoulli's Principle and Heat & Energy

1. A pump is used to drive oil from a pipe to another pipe as shown. The diameter of the wider pipe is 20 cm and the pressure inside is 20 000 Pa while the diameter of the narrower pipe is 10 cm and the pressure inside is 90 000 Pa. The density of the oil is  $800 \text{ kg m}^{-3}$  and flow speed in the wider pipe is  $5 \text{ m s}^{-1}$ .

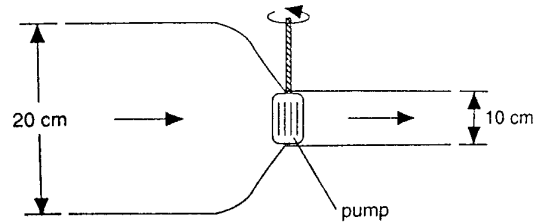

(a) Calculate flow rate of the oil in  $\text{kg s}^{-1}$ .

(b) Calculate the flow speed of oil in the narrower pipe.

(c) Calculate the kinetic energy change per unit mass of oil.

(d) Calculate the work done per unit mass on oil due to the pressure difference.

- (e) If the temperature of the oil is constant, calculate the work done by the pump on each unit mass of oil. Hence calculate the power developed in the pump.

2.

- (a) Figure 2 shows, for isothermal conditions, the graph of pressure,  $P$ , against the reciprocal of the volume,  $1/V$ , for a fixed mass of gas.  
(Given that the molar gas constant,  $R = 8.31 \text{ J mol}^{-1} \text{ K}^{-1}$ )

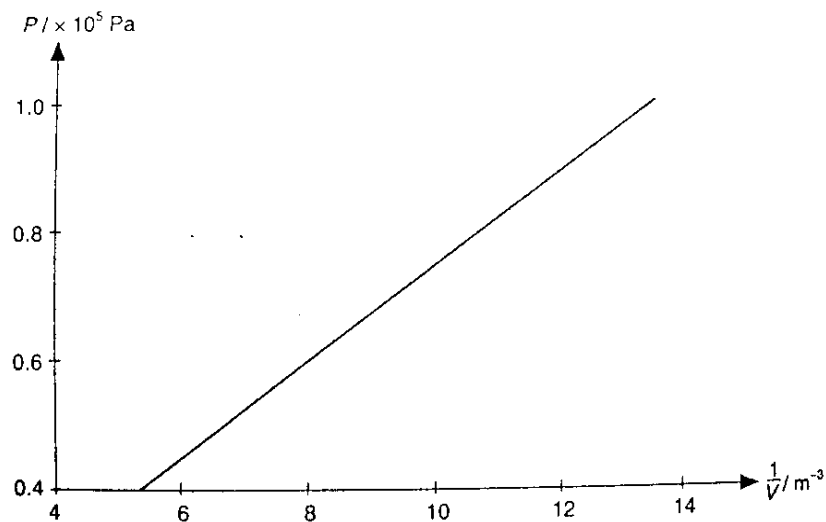

- (i) What is meant by an isothermal change?
- (ii) Use the data from the figure to show that the changes represented by the graph are isothermal.



8. Wave Motion & Acoustics

1.

- (a) Carefully distinguish between the characteristics of progressive and stationary transverse waves, drawing diagrams showing the displacement of the propagating medium particles at selected times during a complete period.

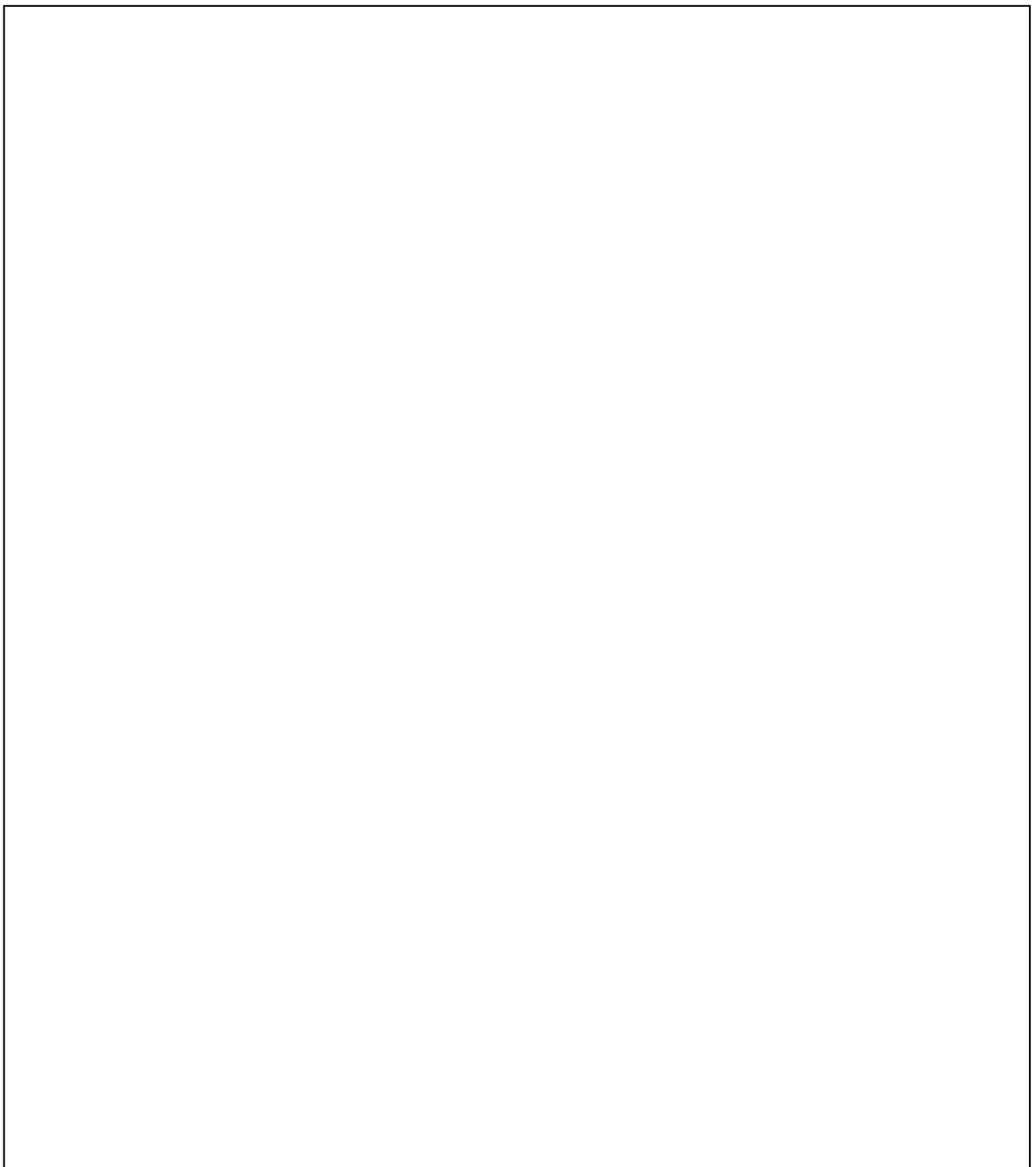

(b) Draw diagrams showing the stationary wave patterns which are excited in

(i) a guitar string,

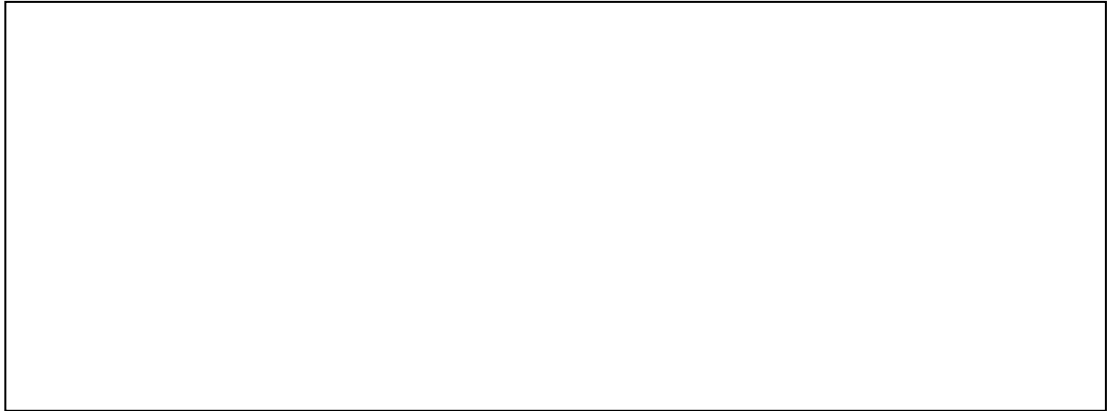

(ii) an open-ended organ pipe and

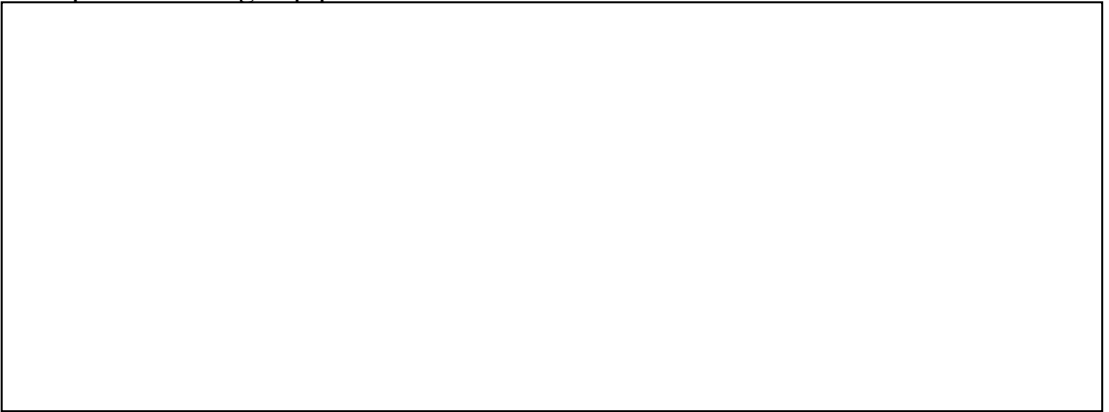

(iii) a closed-end organ pipe,



considering both (1) the fundamental and (2) the first overtone frequencies are related to the appropriate physical dimension of each instrument.

2.

(a)

(i) A certain machine in a factory produces a 65 dB sound level when operating. Taking  $I_0$  as the threshold of hearing, calculate the maximum number of machines which can be operated at the same time in the factory if the noise level is not permitted to exceed 72 dB.

(ii) Suppose the ventilation system of the factory produces a background noise level of 45 dB. Would the total noise level exceed the noise limit of 72 dB when the maximum number of machines as found in (i) are operating in the factory? Explain your answer.

(b) Name one design feature used to lower the noise levels in buildings built near airports or busy highways.

3. A car traveling at  $10 \text{ ms}^{-1}$  sounds its horn, which has a frequency of 500 Hz, and this is heard in another car which is traveling behind the first car, in the same direction, with a velocity of  $20 \text{ ms}^{-1}$ . The sound can also be heard in the second car by reflection from a bridge ahead. What frequencies will the driver of the second car hear? (speed of sound in air =  $340 \text{ ms}^{-1}$ ).



9. Physical Optics

Given: speed of light in air =  $3 \times 10^8 \text{ ms}^{-1}$

1. The figure shows a set-up of Young's experiment. S is a straight filament lamp. The red filter allows monochromatic light of wavelength 700 nm to pass through. Point O is equidistant from slits  $S_1$  and  $S_2$ .

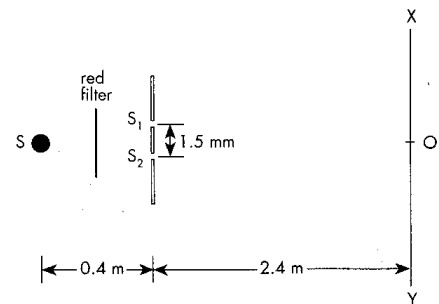

(a) What should be the orientation of the lamp?

(b) The fringes are said to be non-localised. Explain the meaning of this statement.

(c) Discuss the factor(s) determining the number of fringes formed on the screen.

(d) Describe and briefly explain what would be observed on the screen if the filter was removed.

(e) Find the distance of the centre of 5<sup>th</sup> dark fringe from O.

(f) When a thin parallel-sided piece of glass G of refractive index 1.5 and thickness  $3.5 \times 10^{-5}$  m is placed in front of  $S_1$ , the fringe pattern shifts. To which direction and by what distance does the centre of the fringe pattern (the central bright fringe) shift?

2. In a sunny day, Tom wears Polaroid spectacles to reduce the glare of reflected light from water surface or ground. When he is looking at water surface at a glancing angle  $\theta$ , as shown in figure, any reflected light from the surface will be filtered by the spectacles. It is known that speed of light is  $2.25 \times 10^8$  ms<sup>-1</sup> in water. Find the value of  $\theta$ .

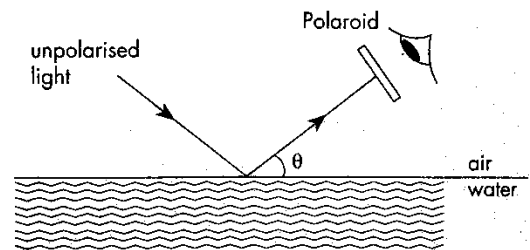

3. In figure (a), a narrow slit S is placed at the focal plane of a convex lens  $L_1$  and is parallel to the lines of the diffraction grating G. After passing through the lens  $L_1$ , the monochromatic light uniformly illuminates the grating. Another convex lens  $L_2$  is placed touching the surface of the grating to focus the diffracted light on a screen at its focal plane. The whole set-up is arranged such that axis X passes through the centre of the screen, the lenses, the grating and the slit (all of which are perpendicular to the axis X).

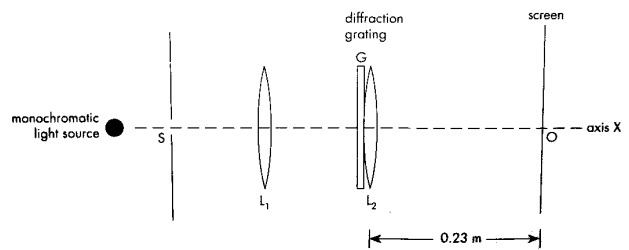

figure (a)

The screen is covered with a graph paper and figure (b) shows the pattern observed on it. It is given that the grating has a width W of 0.04 m and 3000 lines per cm.

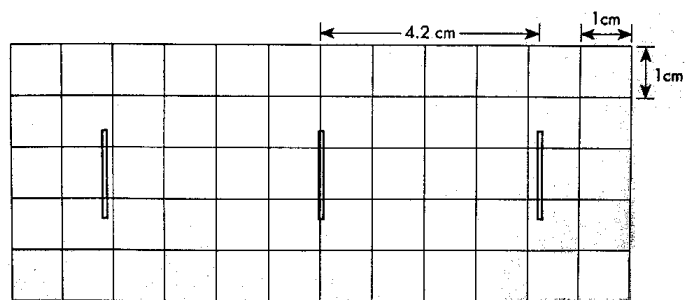

figure (b)

- (a) Find the wavelength of the monochromatic light.

(b) The effective width of the grating is halved by masking the outer areas of the grating with masking tape. In what way(s) do(es) the principal maxima now differ from the original ones and in what way(s) are they similar? Explain your answer.

(c) If the screen is large enough, how many possible lines can be seen on the screen?

(d) The monochromatic source is replaced by a white light source. Sketch on figure (c) the new pattern seen on the screen and label the significant features. Explain your working.

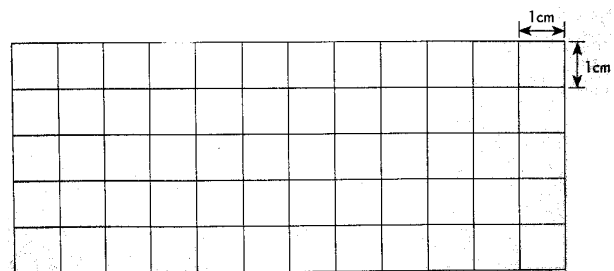
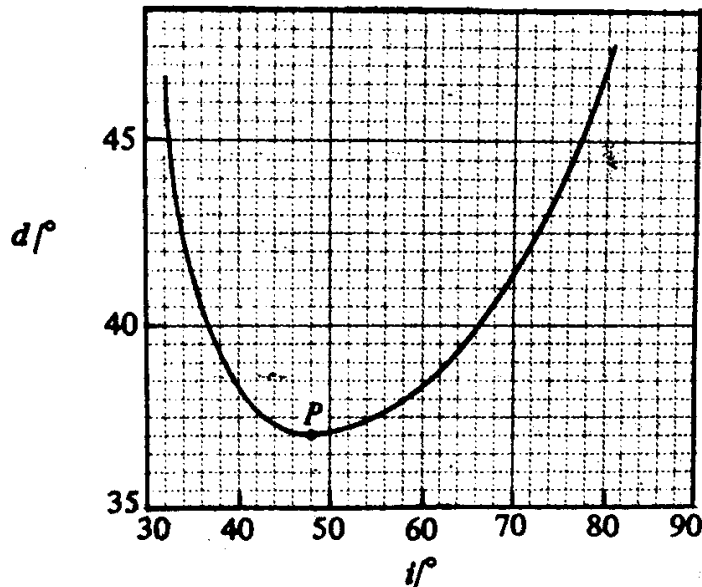

figure (c)

(e) In studying the spectrum of white light as in part (d), we usually look for the first order spectrum instead of higher order spectrum. Why?

10. Geometric Optics

1. The figure shows below the variation of the angle deviation  $d$  of a light ray incident upon a triangular glass prism with angle of incidence  $i$ .



(a) Determine the vertex angle of the prism.

(b) Calculate the refractive index of the prism material.

(c) If the light originally was blue, and this was replaced by red light, discuss qualitatively the effects of this change on the position of the point P on the new graph of  $d$  against  $i$ ? Give your reasons.

2. A compound microscope consists of an objective lens of focal length 1 cm and an eye lens of focal length 5 cm mounted in a tube at a distance of 20 cm from each other. Find where the object must be placed when viewed through the instrument by a person whose nearest point of distinct vision is 25 cm. What adjustment to the microscope would be required if it is then used by a person whose nearest point of distinct vision is 20 cm?

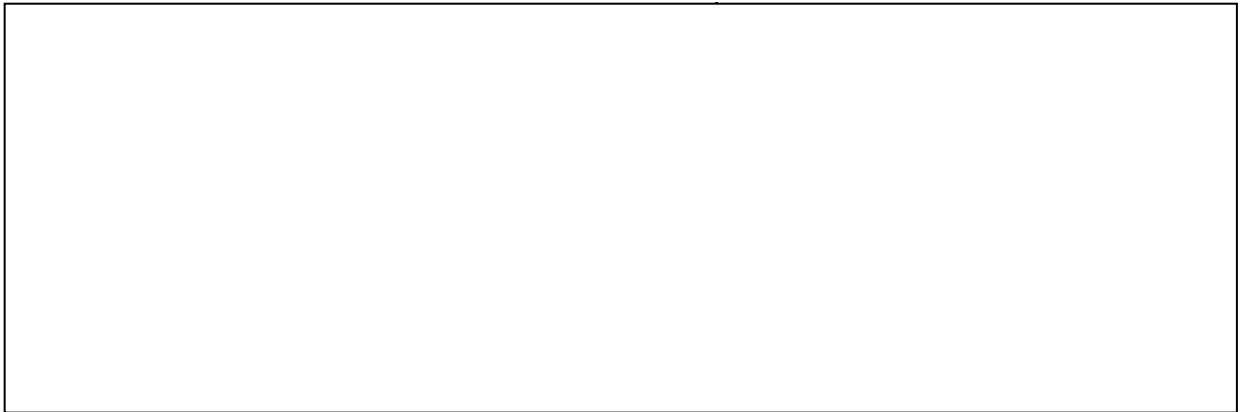

3. An astronomical telescope with an objective of focal length 100 cm and an eyepiece of focal length 3 cm is adjusted so as to project a real image of the sun on a screen 20 cm from the eyepiece. If the diameter of this image is 4.9 cm, calculate the angle subtended by the sun at the centre of the objective of the telescope.

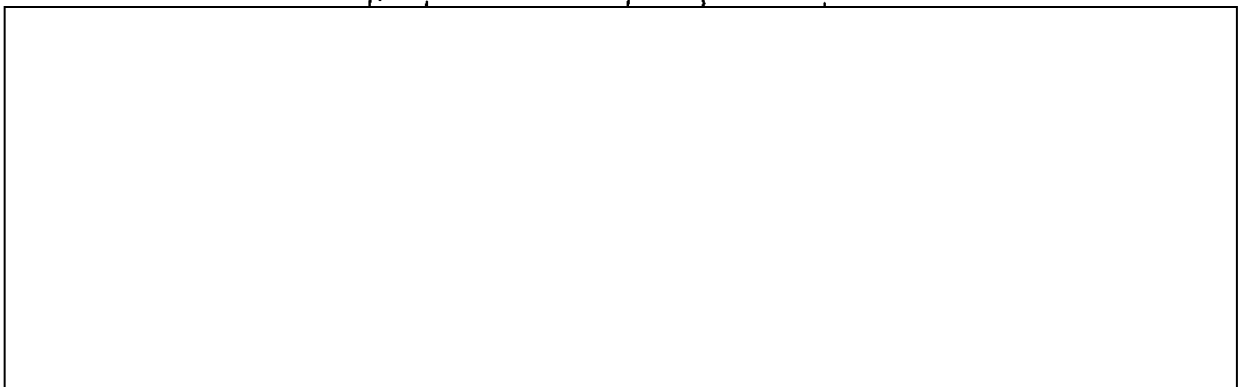

4.

(a) Show, by means of a ray diagram, how an image of a distant object is formed by an astronomical refracting telescope in normal adjustment.

(b) A telescope with objective of focal length 96 cm and diameter 12 cm. Calculate the focal length and minimum diameter of a simple eyepiece lens for use with the telescope, if the magnifying power required is  $\times 24$ , and all the light transmitted by the objective from a distant point on the telescope axis is to fall on the eyepiece.

11. Electric Field & Potential

Given:  $\epsilon_0 = 8.85 \times 10^{-12} \text{ C}^2 \text{ N}^{-1} \text{ m}^{-2}$

1. A sphere of radius  $R$  is an insulator and is supported by an insulated stand as shown in the figure. The potential at the point 500 mm from the centre of the sphere is 400 V.

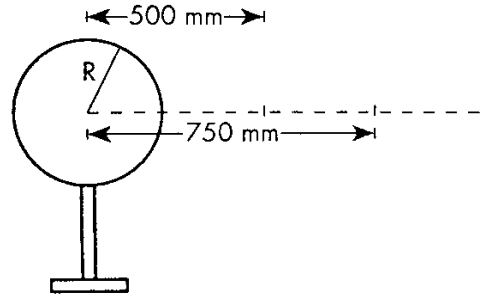

- (a) Determine the potential at the point 750 mm from the centre of the sphere.

- (b) Given that the potential on the surface of the sphere is 800 V, from the above results, determine

- (i) the radius of the sphere,

- (ii) the charge on the sphere.

- (c) Suppose that an identical sphere with potential 800 V on its surface is placed beside the first sphere. The distance between their centers is 1 m.

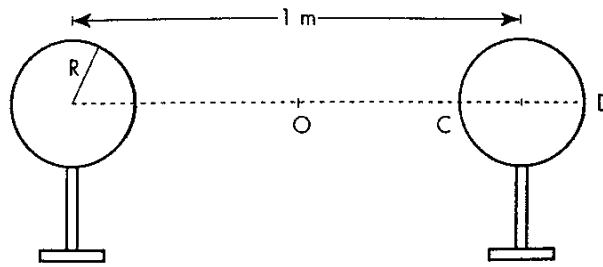

- (i) What will be the potential at point **O** which is the mid-point between the centers of the spheres?
  
- (ii) What will be the potentials at points **C** and **D**?
  
- (iii) Explain briefly why there is an electric field inside the second sphere.
  
- (iv) What will happen to the potential and the charge distribution of the second sphere if it is suddenly coated with a conducting material on its surface?
  
- (v) Suppose that the spheres are replaced by conducting spheres with the same radius and separation. The initial potentials on the surface of each sphere are also 800 V. Is the new potential at point **O** different from the result obtained in part (c) (i)? Give an account for the answer.



2. Two metal plates are located horizontally, as shown in the figure. The plates are 2 mm apart and connected to the terminals of a battery with potential difference  $V$ . The capacitance between the plates is  $20 \times 10^{-10}$  F.

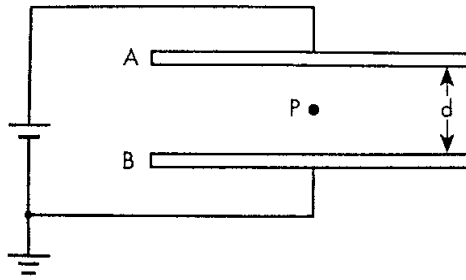

A charged particle of mass  $m = 2$  g and charge  $q$  is placed at position **P** which is in the middle of the plates. Initially, the charged particle is stationary at position **P**.

- (a) Suppose that the upper plate carries charge  $5 \times 10^{-8}$  C, determine the potential of the upper plate  $V_A$ . (Hints:  $CV = Q$ )

- (b) What is the sign of the charges carried by the particle? What is the amount of charge held by the particle?

(c) If the lower plate moves downwards until the distance between the plates is 8 mm, what will happen to the particle? Describe and explain briefly.

(d) Under the condition mentioned in part (c), estimate the kinetic energy of the particle when it strikes the lower plate.

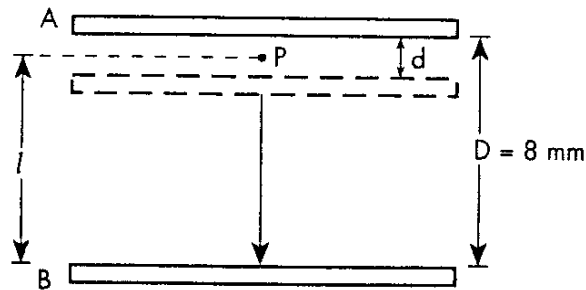

12. Capacitance

Given:  $\epsilon_0 = 8.85 \times 10^{-12} \text{ C}^2 \text{ N}^{-1} \text{ m}^{-2}$

1.

(a) Explain the meaning of the capacitance of a parallel-plate conductor.

(b)

(i) A battery of e.m.f.  $\epsilon$  and negligible internal resistance is connected in series with a resistor of resistance  $R$ , a capacitor of capacitance  $C$  and an open switch. After the switch is closed, derive an expression for the current  $I$  with time  $t$ .

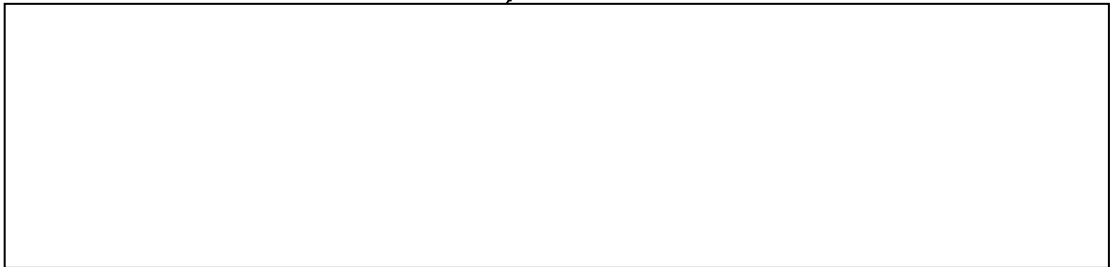

(ii) Derive expressions for  
(1) the work done in charging up the capacitor, and

(2) the energy dissipated in the resistor.

2.

(a)

(i) An isolated metal sphere of radius 1 m is given a charge of  $-1\text{ C}$  on its surface. Find the capacitance and voltage of the sphere.

(ii) A negatively charged conducting sphere is placed inside an earthed metal shell as shown below.

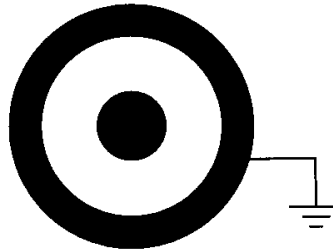

(1) Draw the charge distributions on the sphere and the metal shell, and show the electric field pattern.

(2) How would the capacitance of a conducting sphere be affected by the presence of the earthed metal shell? Explain your answer.

(b) The circuit shown in fig. (a) is used to charge a capacitor  $C$ . Initially the variable resistor  $R$  is set to its maximum value ( $10\text{k}\Omega$ ). When switch  $S$  is closed,  $R$  is adjusted to keep the charging current constant at its initial value. The graph shown in (b) shows how the p.d. across the capacitor  $V_C$  varies with time  $t$  during the first 50 s after closing  $S$ .

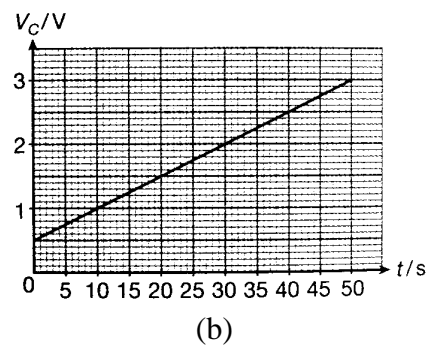
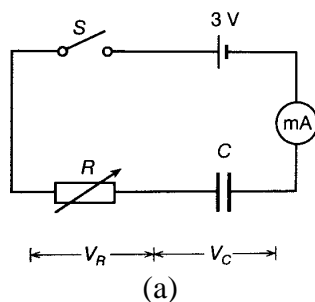

- (i) A student says that the capacitor get charges at  $t = 0$ . Comment on this.
- (ii) Find the initial charging current.
- (iii) Calculate the capacitance of  $C$ .
- (iv) Draw the graph in fig. (b) if  $R$  is initially set at  $4\text{ k}\Omega$ .
- (v) Describe, with a diagram, how you can ensure that the capacitor is uncharged before **S** is closed.

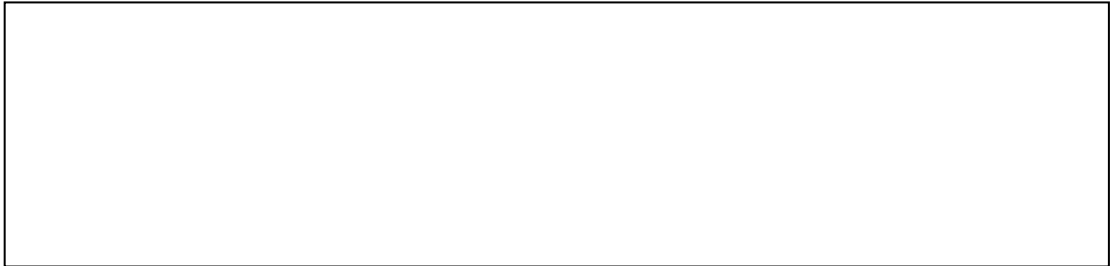

3. Two metal spheres, **A** and **B** of capacitance  $2 \mu\text{F}$  and  $6 \mu\text{F}$  are placed at a very large distance apart. They are both charged with negative charge of  $5 \mu\text{C}$ .

(a) Find the electric potential of each sphere.

(b) Calculate the energy stored by each sphere.

(c) The spheres are then connected by a long conducting wire.

(i) Explain whether there is a flow of charges between the spheres.

(ii) Calculate the final charge and energy stored by each sphere.

(iii) Calculate and account for the energy loss due to the connection.

13. Current Electricity

1. The figure shows below a set-up of a potentiometer. The internal resistance of all cells and all ammeters are negligible. The e.m.f. of cell **X** is 10 V and the resistance of **R<sub>2</sub>** is 100 Ω.

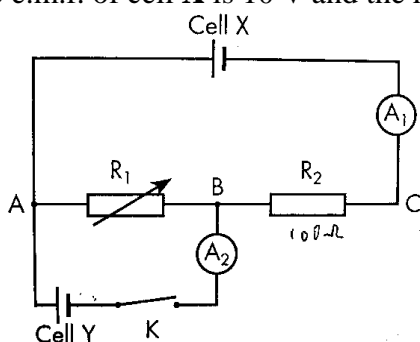

- (a)
- (i) It is observed that ammeter **A<sub>2</sub>** shows a null deflection of current when switch **K** is closed. Given that the resistance of **R<sub>1</sub>** is now 300 Ω, what is the e.m.f. of cell **Y**?
  
  - (ii) Hence determine the reading on ammeter **A<sub>1</sub>** when ammeter **A<sub>2</sub>** shows null deflection.

(b) Can this method be used for determining the e.m.f. of cell **Y** if **Y** has an internal resistance? Explain briefly.

(c) Why is the calibration of ammeter **A<sub>2</sub>** not necessary in the process of determining the e.m.f. of cell **Y**?

(d) Suppose  $R_1$  is  $400\ \Omega$  now and switch  $K$  is closed, determine

(i) the potential difference between points  $A$  and  $B$ ,

(ii) the reading on ammeter  $A_1$ ,

(iii) the reading on ammeter  $A_2$ .

2.

(a) With reference to figure (a), the internal resistance of the source is negligible.

(i) Calculate the potential difference across the fan and the light bulb.

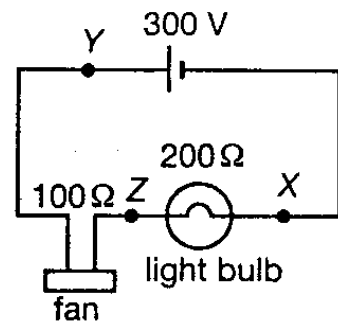

(ii) Describe the energy change when one coulomb of electric charges pass through

(1)  $X$  to  $Y$  through the source,

(2)  $Y$  to  $Z$  through the fan, and

(3)  $Z$  to  $X$  through the light bulb.



(b) Figure (b) shows a battery of e.m.f. 3 V, to which a 1 k $\Omega$  resistor is connected.

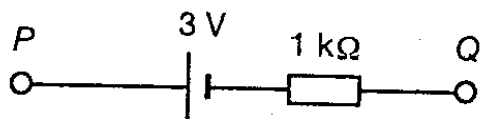

figure (b)

- (i) At first, a student uses a moving-coil voltmeter of internal resistance 5 k $\Omega$  to measure the potential difference across **PQ**. Find the voltmeter reading.
- (ii) Then he connects a CRO across **PQ**. Explain what would the potential difference be measured.

(c) With reference to the circuit shown in figure (c), the cell has negligible resistance and point R is earthed. Sketch a graph of electric potential along **PQRS**.

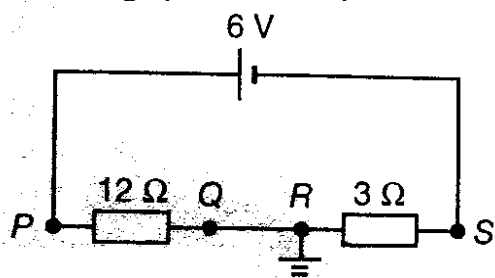
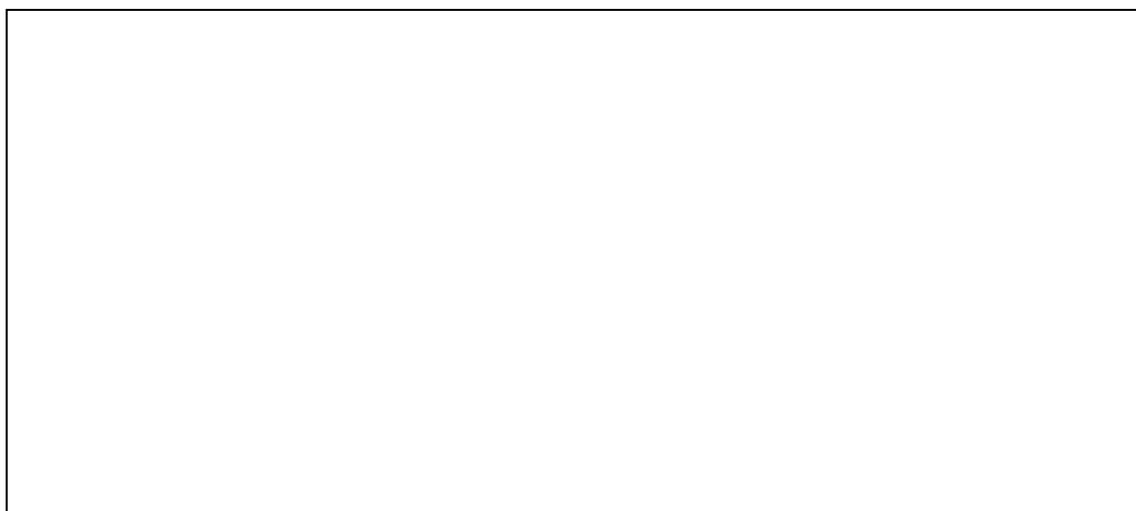
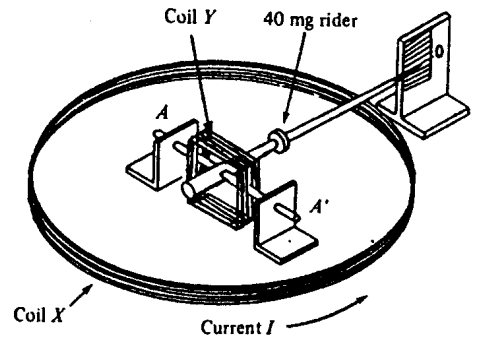

figure (c)



14. Electromagnetism

1. A student sets up the below apparatus to measure current. Coil X is a 100-turn circular coil of mean diameter 300 mm. Square coil Y, also of 100 turns, is pivoted at the centre of Coil X and is free to turn about a horizontal axis AA', in the plane of coil X. When there is no current, the rider is adjusted to make the pointer horizontal.



Coils X and Y are connected in series. When a current  $I$  flows through the coils, the rider has to be moved 80 mm to the right to restore the pointer to a horizontal position.

(Given: magnetic field at the centre of a coil of  $N$  turns  $B = \mu_0 NI/2r$ , permeability of vacuum  $\mu_0 = 4\pi \times 10^{-7} \text{ Hm}^{-1}$ , acceleration due to gravity  $g = 10 \text{ ms}^{-2}$ .)

- (a) In the spaces provided, indicate the direction of the magnetic field produced by coil X at its centre when a current  $I$  flows in the direction shown. Determine the magnetic field  $B$  at the centre of X.

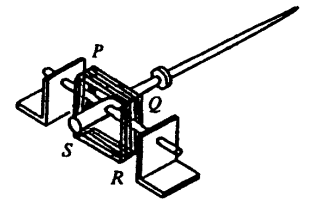

- (b) In which direction should the current in Coil Y be flowing? Indicate the current direction and the corresponding directions of the forces acting on the 4 sides of Coil Y in the diagram below.

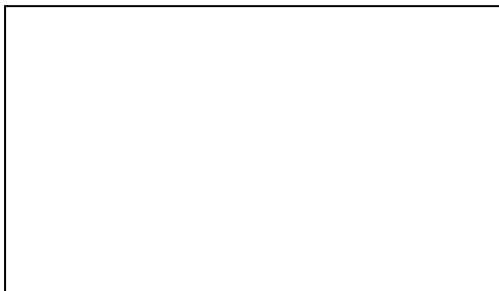

- (c) If the mass of the rider is 40 mg and Coil Y is of side 30 mm, estimate the value of the current  $I$ , assuming that the magnetic field due to coil X is uniform across the coil Y.

- (d) What is the advantage of using this method to measure current?

2.

(a) Faraday's laws of electromagnetic induction may be summarized by the equation  $\mathcal{E} = -d\Phi/dt$ . Explain the physical meaning of this equation, using a coil of wires as an example.

(b) Give brief details of one useful practical example of electromagnetic induction in a coil which involves

(i) movement of the coil;

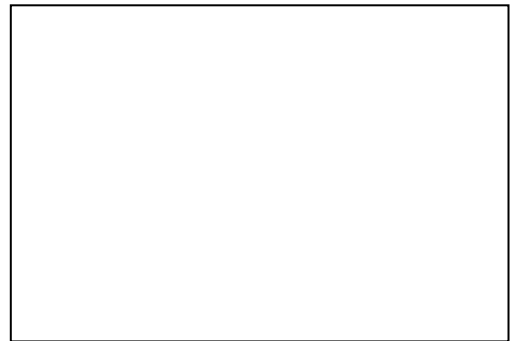

(ii) no movement of the coil.



(c) Explain the effect of electromagnetic induction on

(i) the switching-off of a current supply to an electromagnet; and

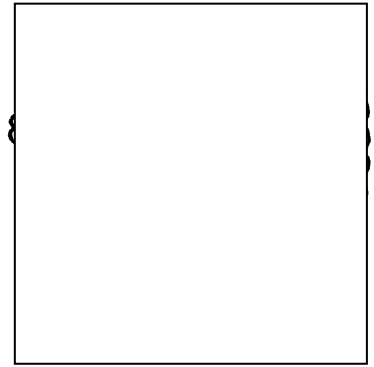

(ii) the heating of a transformer core.

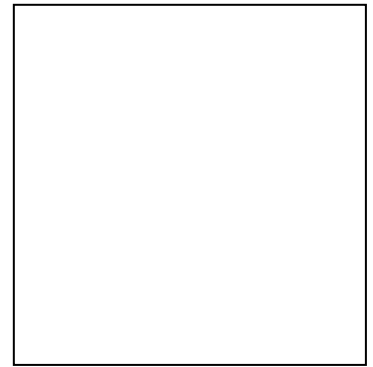

In each case, give a diagram showing the actual instantaneous direction of the induced e.m.f.

(d) Briefly explain suitable precautions which can be taken to minimize the detrimental effects produced by the electromagnetic induction in (c)(i) and (c)(ii).

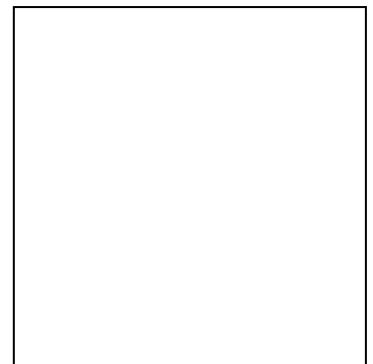

3. A flat circular coil of 100 turns, total resistance  $50 \Omega$  and average area  $0.01 \text{ m}^2$  is placed with its plane perpendicular to a uniform magnetic field of  $0.20 \text{ T}$  as shown in the figure.

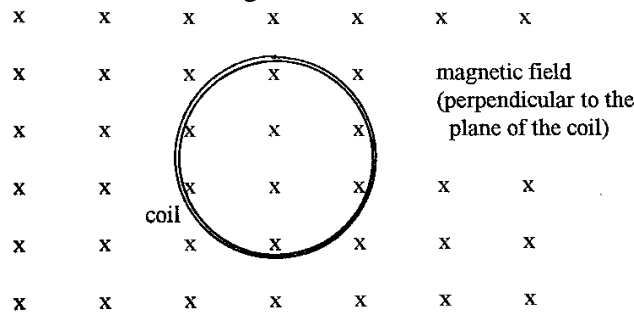

- (a) The coil is rotated through  $180^\circ$  about a diameter (turned upside down) in the short period of time of  $0.1 \text{ s}$ . Calculate, during this period,

(i) the average e.m.f induced in the coil;

(ii) the average current;

(iii) the quantity of charge which flows through a cross-section of the wire in the coil.

- (b) Now the coil is being rotated about a diameter at a uniform rate of 5 revolutions per second. Find

(i) an expression for the current flowing in the coil as a function of time;

(ii) the root-mean-square value of the current;

(iii) the average power dissipated in the coil.

15. Alternating Currents

1.

- (a) When a d.c. voltage of 10 V is applied across a solenoid, a current of 10 mA is recorded by an ammeter with negligible internal resistance. Determine the resistance of the solenoid.

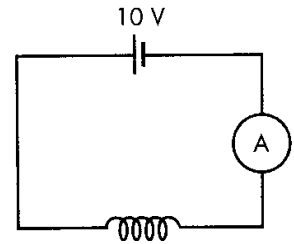

- (b) Now a 50 Hz a.c. voltage of 10 V<sub>rms</sub> is applied across this solenoid. A r.m.s current of 9 mA is recorded by an a.c. ammeter with negligible internal impedance. Determine the inductance of the solenoid.

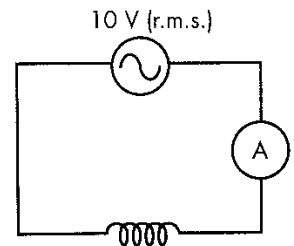

2. The figure shown below is a LRC circuit connected to a sinusoidal signal generator with adjustable output angular frequency  $\omega$ .  $V_1$ ,  $V_2$  and  $V_3$  are three a.c. voltmeters with very high internal resistances.  $A$  is an ammeter with negligible impedance. It is given that  $R = 180 \Omega$ ,  $C = 0.4 \mu\text{F}$  and  $L = 1 \text{ mH}$ .

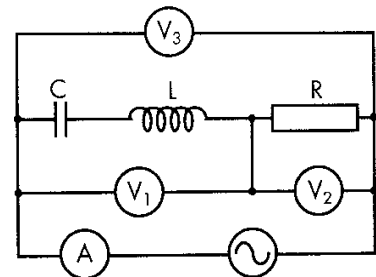

- (a) Find the resonant angular frequency  $\omega_0$  of the circuit.

- (b) At a certain angular frequency  $\omega$ , the readings on  $V_1$  and  $V_3$  are 24 V and 30 V respectively. What is the reading on  $V_2$ ? Explain how you obtain the answer.

3. In the figure below, a power supply provides a sinusoidal voltage of peak voltage 220 V at a frequency of  $f = 50$  Hz to a circuit consisting of a resistor R, an inductor L and a capacitor C. It is given that  $L = 0.5$  H and  $C = 10 \mu\text{F}$ .

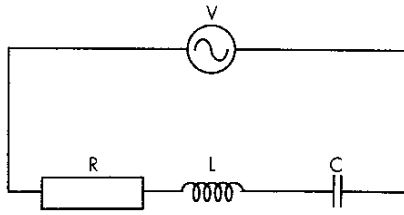

(a) Determine the reactance of the inductor and the capacitor.

(b)

(i) Determine the peak current  $I_0$  if  $R = 100 \Omega$ .

(ii) Find the voltages across the resistor, the inductor and the capacitor if the current is  $I_0 \cos(2\pi f)t$ .

(iii) Express the voltage of the source as function of time.

(c) When the capacitance of  $C$  is changed to a suitable value, the potential difference across  $L$  is the same as that across  $C$ .

(i) Now what will happen to the circuit?

(ii) What is the value of the capacitance?

(iii) What is the peak current flowing through the circuit?

(iv) What are the peak voltages across the resistor, the inductor and the capacitor?

(d) Give a reason why both  $V_C$  and  $V_L$  are larger than  $V_o$ .



16. Extra-nucleus Physics

1.

(a) What does the photoelectric effect imply about the nature of light?

(b) A photocell is connected in the circuit shown in figure 1a. The photocell is an evacuated glass envelope in which two metal electrodes C and E are sealed. A variable potential difference  $V$  is applied between the collector C and the emitter E.  $V$  is taken as positive when C is at higher potential than E.

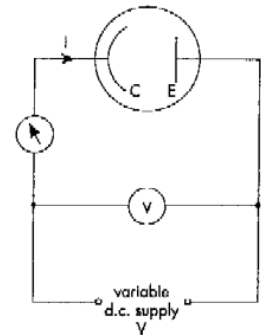

E is illuminated with monochromatic light of wavelength 500 nm and the current  $I$  in the circuit is measured for various values of  $V$ . The results are shown in figure 1b.

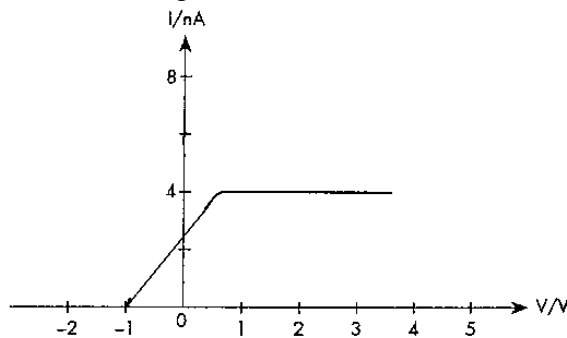

(i) Find the work function of the emitter E. Express your answer in eV.

(ii) What is the maximum speed of the emitted photoelectrons? Take mass of an electron to be  $9.1 \times 10^{-31}$  kg.

(iii) Find the rate of production of photoelectrons at the emitter.

(c) The experiment in part (b) is repeated with the intensity of light falling on the photocell being doubled.

(i) On figure 1c, sketch a new graph of  $I$  against  $V$ .

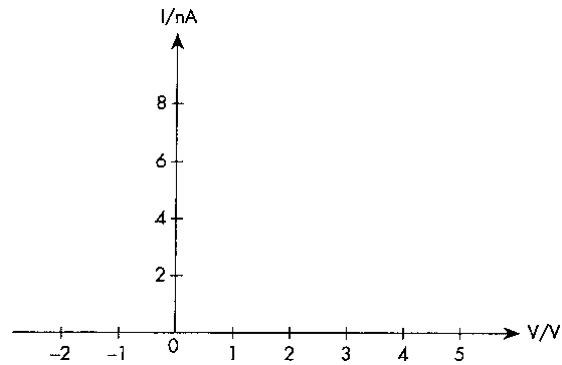

(ii) Explain why the graph in part (c)(i) contradicts the wave theory of light.

(iii) Write a few words to explain your answer in part (c)(i).

2. Figure 2a shows a Coolidge type X-ray tube.

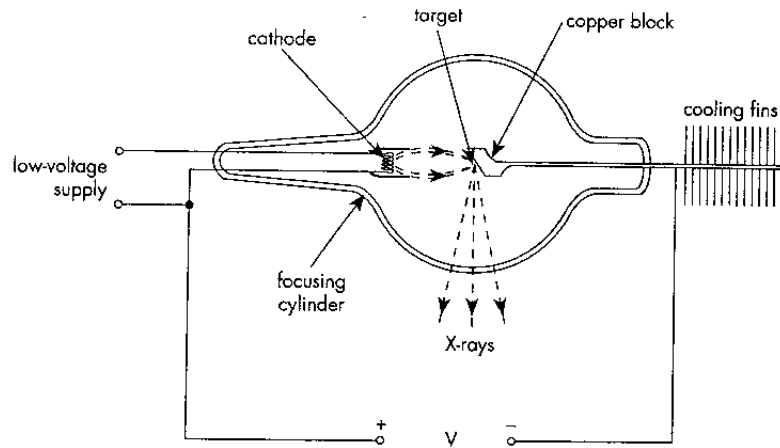

A high voltage  $V$  is applied across the cathode and the anode. When the electrons strike the target, X-rays are emitted with the spectrum shown in figure 2b. The current passing through the tube is 20 mA.

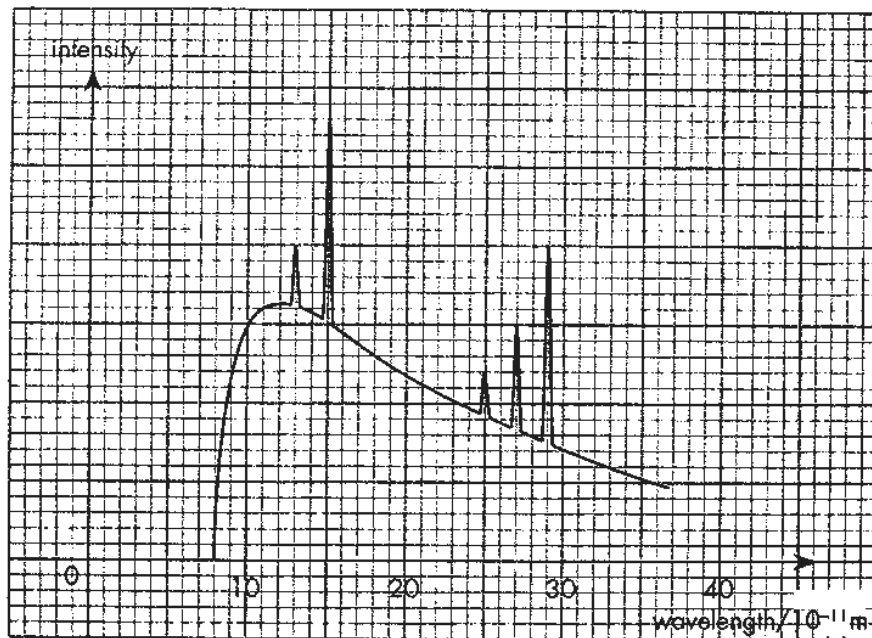

(a) Describe how the continuous background radiation is produced.

(b)

(i) What is the maximum energy of the emitted photon?

(ii) Find the value of  $V$ .

(iii) Only 0.5% of the total energy of the cathode rays is converted into X-ray. What is power of the emitted X-rays?

(c) Point out the essential difference between production of X-ray line spectra and optical atomic emission spectra.

(d) On figure 2b, sketch a graph to show how the intensity of the X-rays emitted varies with wavelength if the accelerating voltage is reduced by half. Label this curve as A.

(e) Sketch another curve on figure 2b, similar to that in part (e), if the current in the filament is increased with the accelerating voltage unchanged. Label this curve as B.

17. Radioactivity & Nuclear Physics

1. Figure 1 shows an ionization chamber linked to a 0 – 500 V variable voltage supply and a very sensitive meter with a range of 0 - 100 pA ( $1 \text{ pA} = 10^{-12} \text{ A}$ ). The apparatus can be used to measure the activity of an alpha source.

Given: electron charge =  $1.6 \times 10^{-19} \text{ C}$ , 1 year =  $3.156 \times 10^7$  seconds

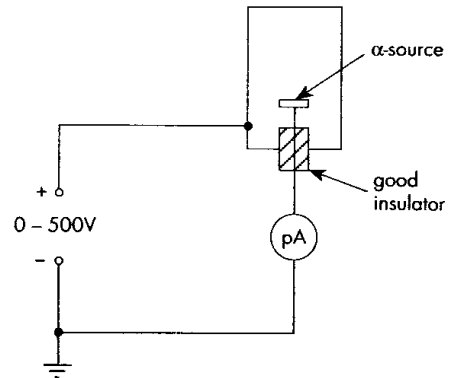

(a) When the voltage supply was increased from 300 V to 400 V, the current recorded on the meter increased from 60 pA to 72 pA, but when the voltage supply was further increased to 500 V the current remained at 72 pA. Suggest a reason in each case why

(i) the first increase in voltage supply raised the current;

(ii) but the second increase in voltage supply did not.

(b) The supply voltage is set at 500 V. Find the number of air molecules ionized in the chamber in one second.

(c) The energy of each emitted alpha particle is 5.4 MeV and the average ionization energy of the molecules of air is 30 eV.

(i) Estimate the activity of the source.

(ii) It is known that range of the alpha particles in air is approximately 30 mm. Estimate the average number of ionization produced per mm of path of an alpha particle. Suggest a reason why the number of ionization per mm increases towards the end of the path.

(d) If the source has a half-life of 5000 years, find the number of radioactive nuclei inside the source.

(e) If the volume of the chamber is reduced significantly, what would be the effect on the saturated ionization current? Explain briefly.

2. Given: Permittivity of free space =  $8.85 \times 10^{-12} \text{ F m}^{-1}$ , electron charge =  $1.6 \times 10^{-19} \text{ C}$ , Avogadro constant =  $6.0 \times 10^{23} \text{ mol}^{-1}$ , molar gas constant =  $8.3 \text{ J mol}^{-1} \text{ K}^{-1}$ , speed of light =  $3 \times 10^8 \text{ m s}^{-1}$ , atomic mass unit =  $1.66 \times 10^{-27} \text{ kg}$

A new energy source could be realized by bringing about the fusion of two deuterium atoms ( $^2\text{H}$ ). In the fusion process, deuterium would form helium-4 and release considerable quantity of energy.

(a) However, the nuclear force is short-ranged and the two deuterium atoms would have to be brought together within  $10^{-14} \text{ m}$  before fusion occurs.

(i) Assuming that all molecules in the gas of deuterium travel at the same speed, estimate the temperature to which the gas would have to be raised to provide sufficient kinetic energy for successful fusion.

(ii) Explain why we might expect some products from a fusion reaction at a temperature much lower than that found in part (a)(i) above.

(iii) Explain why we might expect some products from a fusion reaction at a temperature much lower than that found in part (a)(i) above.

(b) If technology can be improved, the following fusion reaction may be used as an energy source.

(i) The neutron mass is 1.00898 u, the proton mass is 1.00759 u, the nuclear masses of deuterium and helium are 2.01419 u and 4.00277 u respectively. Find the energy released per each gram of deuterium used.

(ii) Deuterium is plentiful in the ocean. Natural hydrogen contains 0.015% of deuterium. Assuming that the ocean is of mass  $1.43 \times 10^{24}$  g and contains pure water of which 50% deuterium could be obtainable and the overall efficiency of the fusion process is 30%, estimate the total energy obtainable from fusion.

(c) Give two advantages of the production of nuclear energy by fusion process instead of fission process.

(d) However, it has proved impossible to use nuclear fusion for large-scale generation of electrical energy. State two main difficulties in producing controlled fusion.